



Auxiliary Air Suspension



Installation Manual

L.RAN.08.C.M

Ford Ranger 4WD, ABS (2000 -Present)
Mazda B-series 4WD, ABS(2000 - Present)





Ford Ranger

Mazda B-series

L.RAN.08.C.M

CONTENTS

1. FOREWORD	3
2. INTRODUCTION	4
3. VERY IMPORTANT NOTES.....	5
4. COMPLETE ASSEMBLY	6
5. INSTRUCTIONS FOR INSTALLATION	8
5.1. Recommended Tightening Torque.....	8
5.2. Installation of lower plate.....	8
5.3. Attaching top plate to chassis	9
5.4. Attaching the air spring to the top plate	9
5.5. Attaching the air spring to the lower plate	9
5.6. Spring alignment	9
5.7. Fitting of Inflator Console.....	10
5.8. Tube Connection and Disconnection, Cutting and Routing	11
5.9. Spring Inflation.....	12
5.10. Maintenance.....	12
5.11. Installation Drawings	13
6. EPILOGUE	16

Dunlop Systems and Components
 Het Wegdam 22
 7496 CA Hengevelde
 Nederland
 Tel. +31 (0)547 33 30 65
 Fax. +31 (0)547 33 30 68

Dunlop Systems and Components
 Holbrook Lane
 Coventry CV6 4QX
 United Kingdom
 Tel. +44 (0)24 7629 3300
 Fax. +44 (0)24 7629 3390

www.dunlopsystems.com

© 2008, *Dunlop Systems and Components*



Ford Ranger

Mazda B-series

L.RAN.08.C.M

1. FOREWORD

This manual provides instructions for the installation of an auxiliary air suspension kit, developed specifically for the Ford Ranger and the Mazda B2300, B2500, B3000 and B400. To ensure correct installation of the kit, it is strongly recommended that these instructions are read thoroughly before commencing any installation work. Installation should only be carried out by a suitably qualified mechanic or specialist installation facility. Dunlop Systems and Components will not accept any responsibility for faults or defects arising from incorrect installation, which automatically renders the guarantee invalid.

IMPORTANT : Manufacturer's Declaration Form

A manufacturer's declaration form is provided with your kit. Following installation of the kit please ensure that this form is completed and signed by a qualified fitter, and that a copy is returned to Dunlop Systems and Components by post, fax or e-mail.



Ford Ranger

Mazda B-series

L.RAN.08.C.M

2. INTRODUCTION

Thank you for choosing an auxiliary air suspension kit from the range offered by *Dunlop Systems and Components*. Auxiliary air suspension is fitted in tandem with the standard steel springs of the vehicle suspension, and provides enhancements in terms of both the stability of the vehicle and the comfort of the passengers...

Vehicle Levelling

Simply by varying the air pressure in the springs, the vehicle can be levelled both front-to-rear and side-to-side. Keeping the vehicle level optimises stability, ensures correct headlamp beam distribution and reduces tyre wear arising from uneven distribution of weight.

Straight Line Stability

Straight line stability is greatly increased at higher speeds, and when subjected to buffeting from cross-winds or large overtaking vehicles.

Reduced Body Roll

Body roll when cornering or negotiating roundabouts is significantly reduced.

Fatigue Reduction and Wear Compensation

Suspension fatigue is reduced, so helping to prevent leaf springs from sagging under repeated or constant loading.

Any sagging already present can be compensated-for. This is a particular benefit for motorhomes, which are always fully laden.

Ride Comfort

Air springs help to absorb shock loads from uneven road surfaces, therefore general ride quality is much improved.



Ford Ranger

Mazda B-series

L.RAN.08.C.M

3. VERY IMPORTANT NOTES



Gross Vehicle Weight (GVW)

Air assist kits are not in themselves designed to increase the gross vehicle weight (GVW) rating of a vehicle. They do not legally allow for carriage of a load greater than the carrying capacity stated on the data plate of the vehicle.

Do not exceed the maximum load specified by the vehicle manufacturer...

- ◆ to avoid compromising passenger safety
- ◆ to prevent possible damage to the vehicle
- ◆ for legal reasons

Vehicle Upgrading

Despite the above words of caution, it is possible to upgrade the weight rating of your vehicle. This must be carried-out by a specialist supplier that will...

- ◆ carry out any necessary modifications in addition to fitting the air assist kit
- ◆ complete documentation as necessary to inform the Vehicle and Operator Services Agency (VOSA) – a mandatory requirement
- ◆ supply and fit a new weight plate to replace the original plate supplied with the vehicle

This process applies to United Kingdom registered vehicles. The process in other countries may be different.

Safety Guidance Note

The following very useful guidance note is available for free download from the *Health and Safety Executive (HSE)*...

PM85, July 2007 *Safe recovery (and repair) of buses and coaches fitted with air suspension*

The uniform resource locator (URL) for this document is...

<http://www.hse.gov.uk/PUBNS/pm85.pdf>



Ford Ranger

Mazda B-series

L.RAN.08.C.M

4. CONTENTS OF THE AUXILIARY AIR SUSPENSION KIT

Your kit should contain the parts below. If this is not the case then please contact your dealer and replacement parts will be provided as soon as possible.

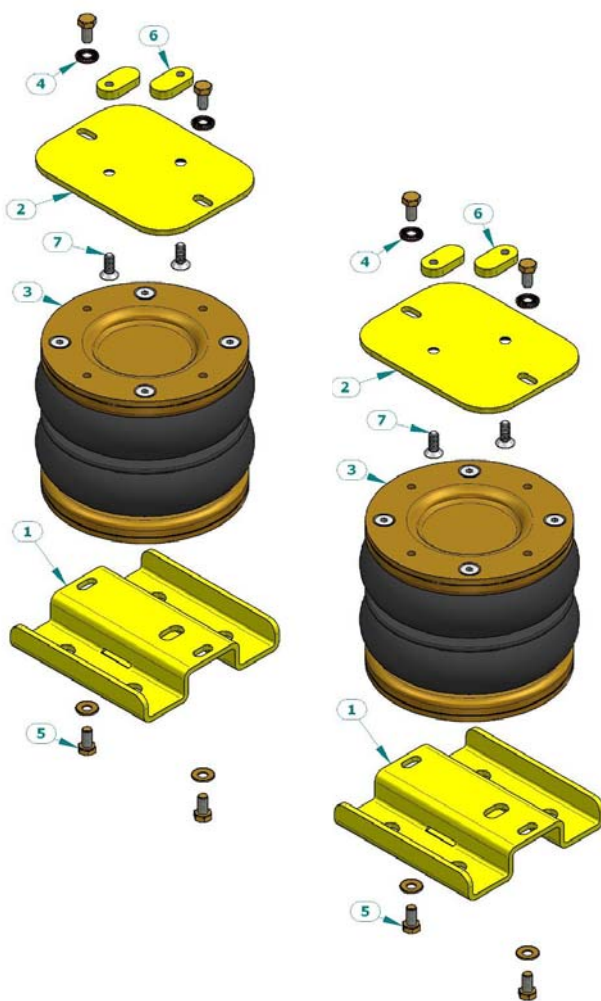

Ref.	Part No.	Part	Count
1	21.07.00.1.04	Lower Bracket	2
2	21.07.00.1.01.01	Upper Bracket	2
3	OP.LB.170-2.CPL	Air Bellow 170/2	2
4	37280.080.001	Disc spring M8	8
5	21.07.00.1.04	Hexagon bolt M8 x 16	8
6	21.07.00.1.02	Fixation plate	4
7	DIN7991 M8 x 20	Counter sunk Imbus bolt	4



Ford Ranger

Mazda B-series

L.RAN.08.C.M

Also contained within the kit of parts are the following:

- * 1 Blue Air Hose (right)
- * 1 Black Air Hose (left)
- * Cable Ties
- * Manual
- * Declaration of EU Conformity

For inflation of the air suspension you will have inflation valves (S) or option 1, 2 or 3.

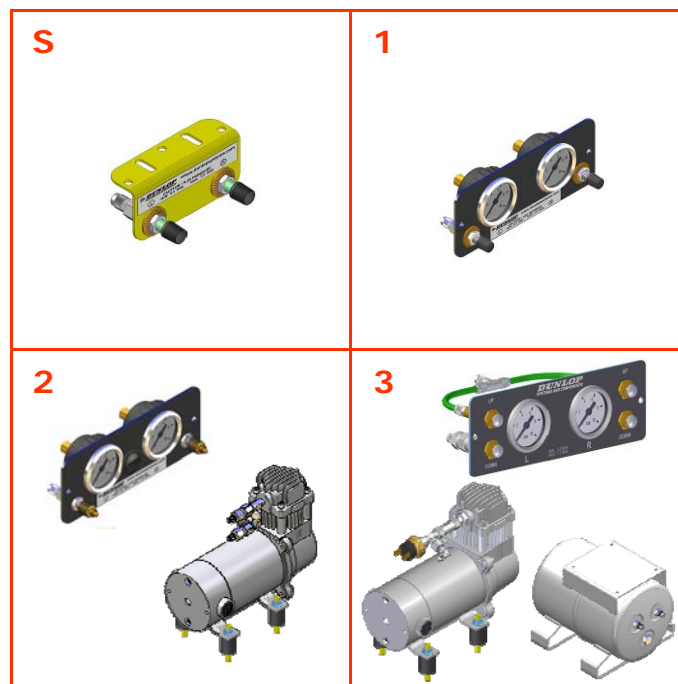

- S. **Standard** : Inflation valves
- 1. **Option 1** : Gauges with valves
- 2. **Option 2** : Gauges with valves and compressor
- 3. **Option 3** : Gauges with valves, compressor and tank



Ford Ranger

Mazda B-series

L.RAN.08.C.M

5. INSTRUCTIONS FOR INSTALLATION



Preparation and Precaution



Before beginning installation, ensure that you have sufficient clearance between the axle and the chassis (at least 25cm). Use a jack if necessary. Install at one side of the vehicle at a time.



Pay attention to your safety at all times during installation - always use axle stands to support the vehicle!

5.1 Recommended Tightening Torque

During fitting of the air suspension system, it is recommended that nuts and bolts are tightened in accordance with the following table...

METRIC TORQUE CHART in N.m			
SIZE	CLASS 8.8	CLASS 10.9	Aluminium and PA6G
M6 x 1	10	14	4
M8 x 1.25	23	34	9
M10 x 1.5	48	67	18
M12 x 1.75	83	117	31
M16 x 2	200	285	80

- When both the bolt and nut are made from steel use either class 8.8 or 10.9
- For all other materials, tightening torque is left to the discretion of a person skilled in the art

The following instructions make reference to the diagrams on pages 16 to 18 inclusive.

5.2 Installation of lower plate

1. Clean the screw winding of the u-bolts if necessarily
2. Loosen the U-bolts and remove the fixation plate. (pictures 1 to 3)
3. Position the lower plate on top of the leaf springs with the hole for the air hose pointed to the inside of the chassis. (picture 4 and 5)
4. Tighten the U-bolts equally. (picture 6)

**L.RAN.08.C.M****5.3 Attaching top plate to chassis**

1. Insert the small fixation plates into bump stop rebound. (picture 7 & 8)
2. Connect the top plate with the two M8 x20 counter sunk bolts. (picture 9—11)

5.4 Attaching the air spring to the top plate

1. Guide the air hose from the underside through the designated hole.
2. Connect the air hose to the air bellow Use blue for the right hand side and black for the left hand side. (see page).
3. Connect the air bellow finger tight to the top plate.

5.5 Attaching the air spring to the lower plate

1. Guide the air hose trough the designated hole.
2. Connect the air bellow finger tight to the bottom plate.

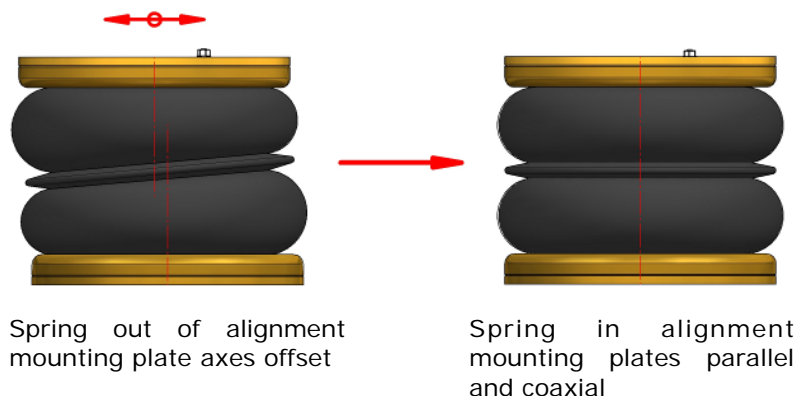
5.6 Spring Alignment**CAUTION!**

Before fully tightening the bolts that secure the air spring to the upper and lower brackets, set the vehicle at ride height (spring height approximately 13.5cm) and ensure that the springs are correctly aligned.



L.RAN.08.C.M

5.7 Fitting of Inflator Console

Standard



Option 1

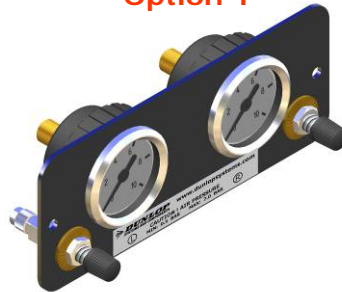

Option 2



Option 3



Your kit is supplied with one of the inflator console options shown above...

- 'Standard', having two valves only (above, top-left)
- 'Option 1', 'Option 2' or 'Option 3', having both valves and pressure gauges

Mount the console in a position of your choice whereby it is firmly fixed, has some protection from the environment (particularly important for the console with gauges) and is easily accessible. Suggested possible locations include...

'Standard' Console...

- on the rear bumper
- at the rear beside the license plate
- on the chassis next to a rear wheel
- in a service shutter
- beside the fuel cap

'Option 1', 'Option 2' or 'Option 3' Console...

- in the vehicle cabin, within reach and sight of the driver
- in the wall of a cupboard (motorhomes)
- in a service shutter

'Comfort' Packages

The 'Option 2' and 'Option 3' panels, as shown above, are each part of a *Comfort Package* that is supplied with a compressor (and also an air reservoir in the case of the 'Option 3' panel) for ease of spring inflation and ride height setting. For further information please ask your dealer.



L.RAN.08.C.M

5.8 Tube Connection and Disconnection, Cutting and Routing

Connection and Disconnection

Tubes are connected as shown by the diagrams below...

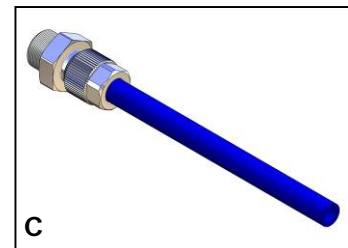
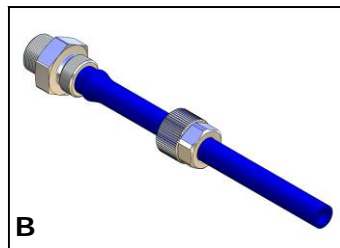
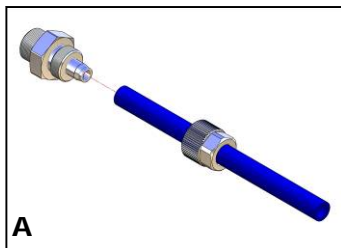

- Slide a nut over the end of the tube
- Push the tube onto the connector as far as possible
- Feed the nut up to the connector, fully tighten by hand and finally tighten one additional turn using spanners

Cutting

To achieve good sealing and air-tight fitting of tube ends to their connecting parts, it is very important to cut tubing cleanly and squarely. A dedicated guillotine action tubing cutter is recommended, or a craft knife if such a tool is not available. Do not use electrician's side cutters.



A dedicated tubing cutter -
Recommended



Electrician's Side Cutters
NOT Recommended

Routing

Study the underside of the vehicle and decide how to route each branch of the air circuit...

- To minimise the risk of chafing, avoid running tubing over metal edges as much as possible
- Avoid close proximity to heat sources such as the exhaust assembly
- Choose a route that provides as much protection as possible from dirt, debris and any solid objects that may impact the underside of the vehicle



Ford Ranger

Mazda B-series

L.RAN.08.C.M

It is recommended that tubes are guided alongside brake lines as much as possible.



Use cable ties ('tie wraps') to secure tubing to the chassis, taking care not to over-tighten them.

5.9 Spring Inflation

Once installation of the air assist kit is complete, inflate the springs via the inflator console taking careful note of the following...



Maximum and Minimum Pressure

Maximum Pressure 7.0bar

Minimum Pressure 0.5bar

Do not exceed 7.0bar (101psi), which is the recommended maximum charge pressure for the air springs.

The springs may be deflated if the vehicle is to be stored for a lengthy period without use, but a pressure of at least 0.5bar (7.25psi) should be maintained at all times in order to avoid possible compression damage to the springs.

It is wise to hand over the vehicle 24 hours after the installation is done. Just to assure the customer will leave with an airtight system.

5.10 Maintenance

Following installation, it is recommended that all metal parts are coated with a protective substance such as body wax.

The system does not require very much maintenance other than...

- ◆ to maintain air pressure in the springs. Much like a tyre, the system may lose a little air over time.
- ◆ to keep the air bellows clean. It is suggested that, when washing the vehicle, the bellows are inspected and cleaned as necessary (preferable by spraying). Look in particular for stones or grit trapped between convolutes, as this may damage the bellow.
- ◆ Check before and after the winter period the wax coating. Re-wax when necessarily



Ford Ranger

Mazda B-series

L.RAN.08.C.M

5.11 Installation drawings

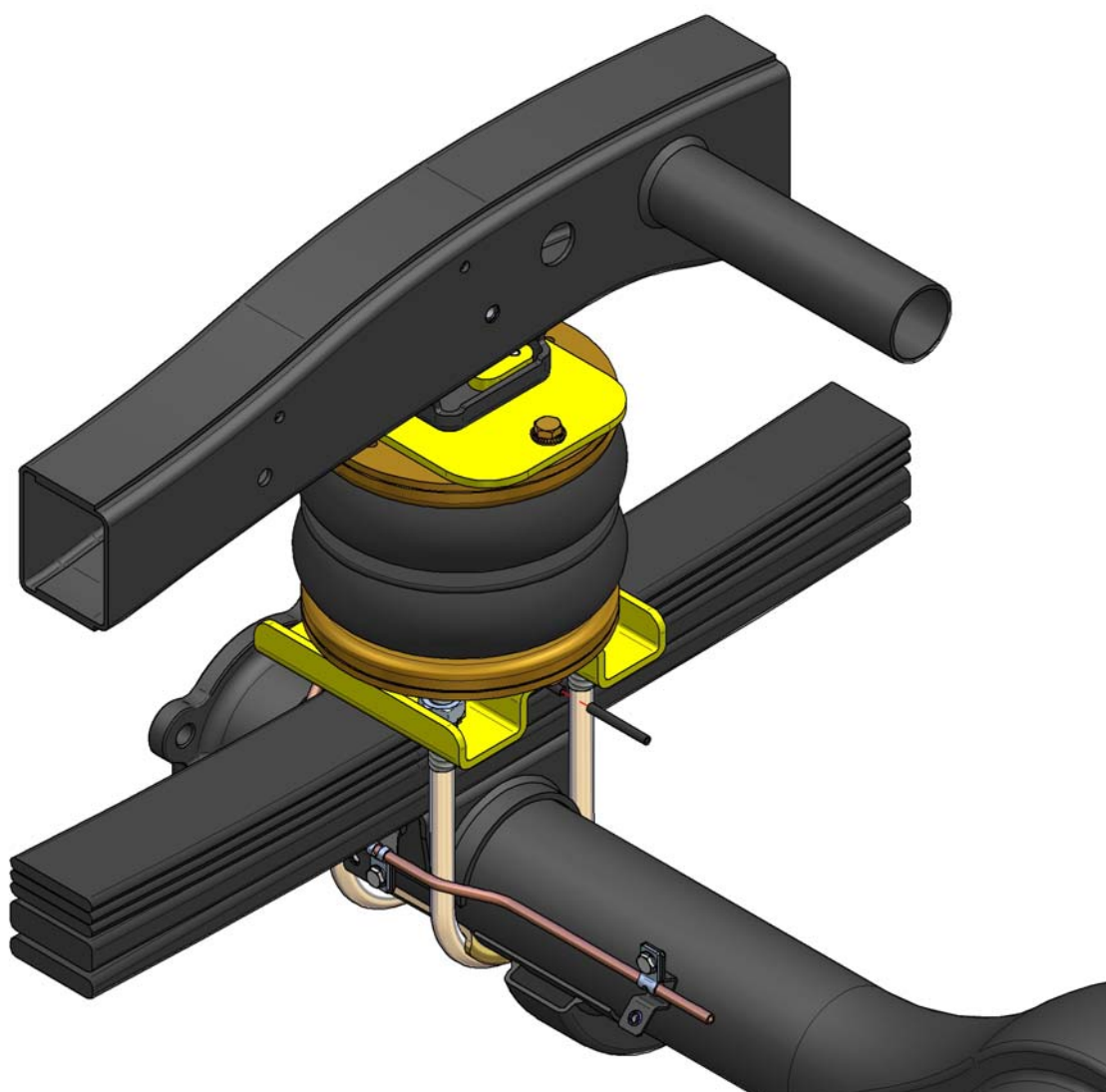



Ford Ranger

Mazda B-series

L.RAN.08.C.M

1



2

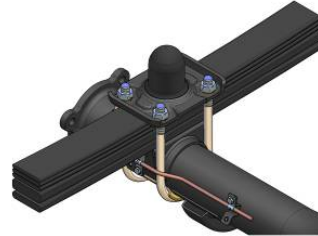

3

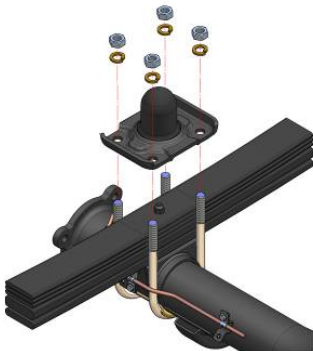

4

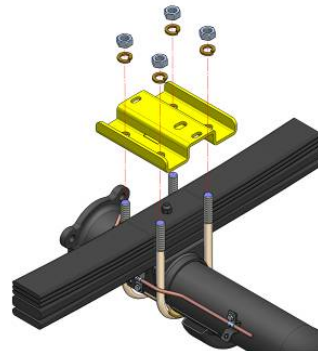

5

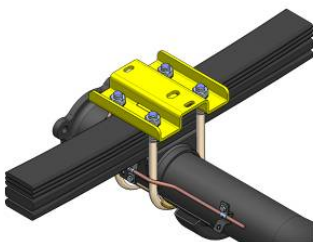

6

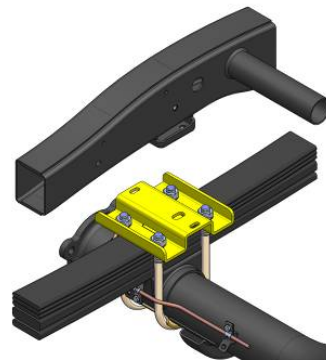

7

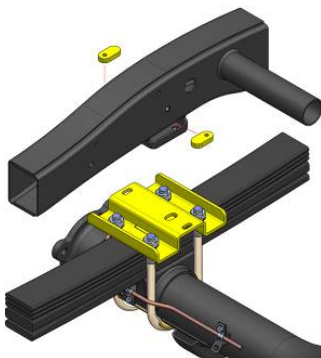

8

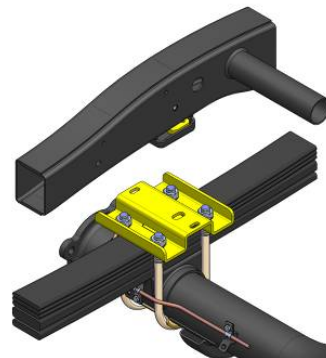



Ford Ranger

Mazda B-series

L.RAN.08.C.M

9

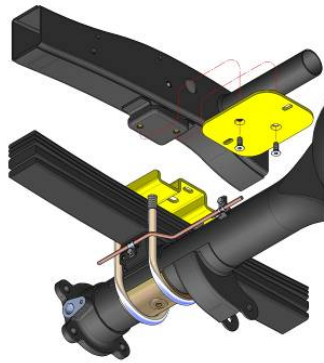

10

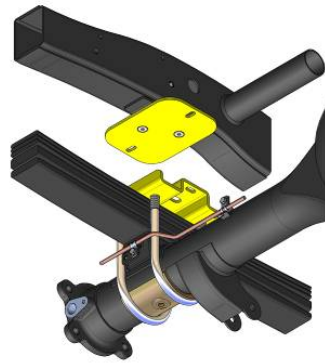

11

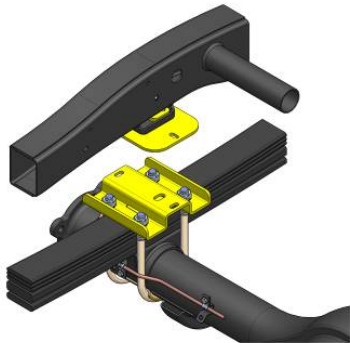

12

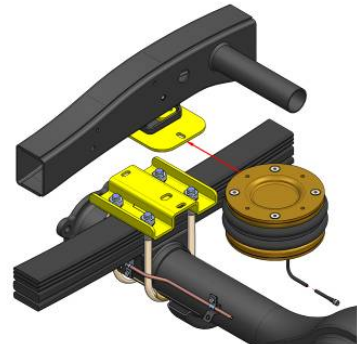

13

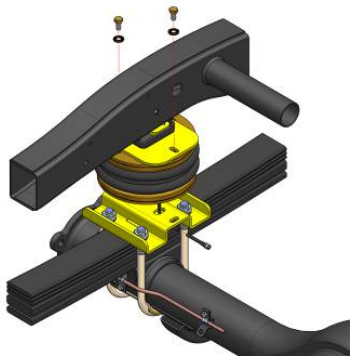

14

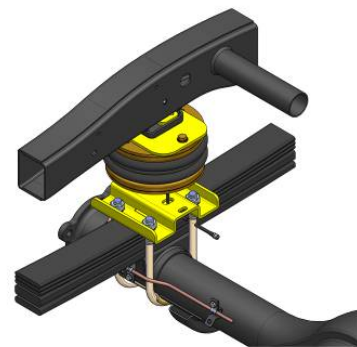

15

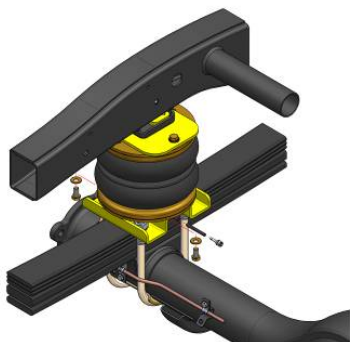

16





Ford Ranger

Mazda B-series

L.RAN.08.C.M

6. EPILOGUE

Dunlop Systems and Components hopes that you enjoy the benefits that your air suspension system will provide for you. To ensure optimal performance, we advise that you have your system checked frequently by qualified personnel. As recommended in the fitting instructions, it is important to coat all the steel parts with a protective substance such as body wax.

IMPORTANT : Manufacturer's Declaration Form

A manufacturer's declaration form is provided with your kit. Following installation of the kit please ensure that this form is completed and signed by a qualified fitter, and that a copy is returned to Dunlop Systems and Components by post, fax or e-mail.

As a condition of your warranty, modifications to the system may only be carried out by personnel of Dunlop Systems and Components or an appointed agent.

Enquiries

For general enquiries please either telephone...

Dunlop Systems and Components Nederland : +31 (0)547 33 30 65

Dunlop Systems and Components UK : +44 (0)24 7629 3300

...or e-mail info@dunlopsystems.nl.

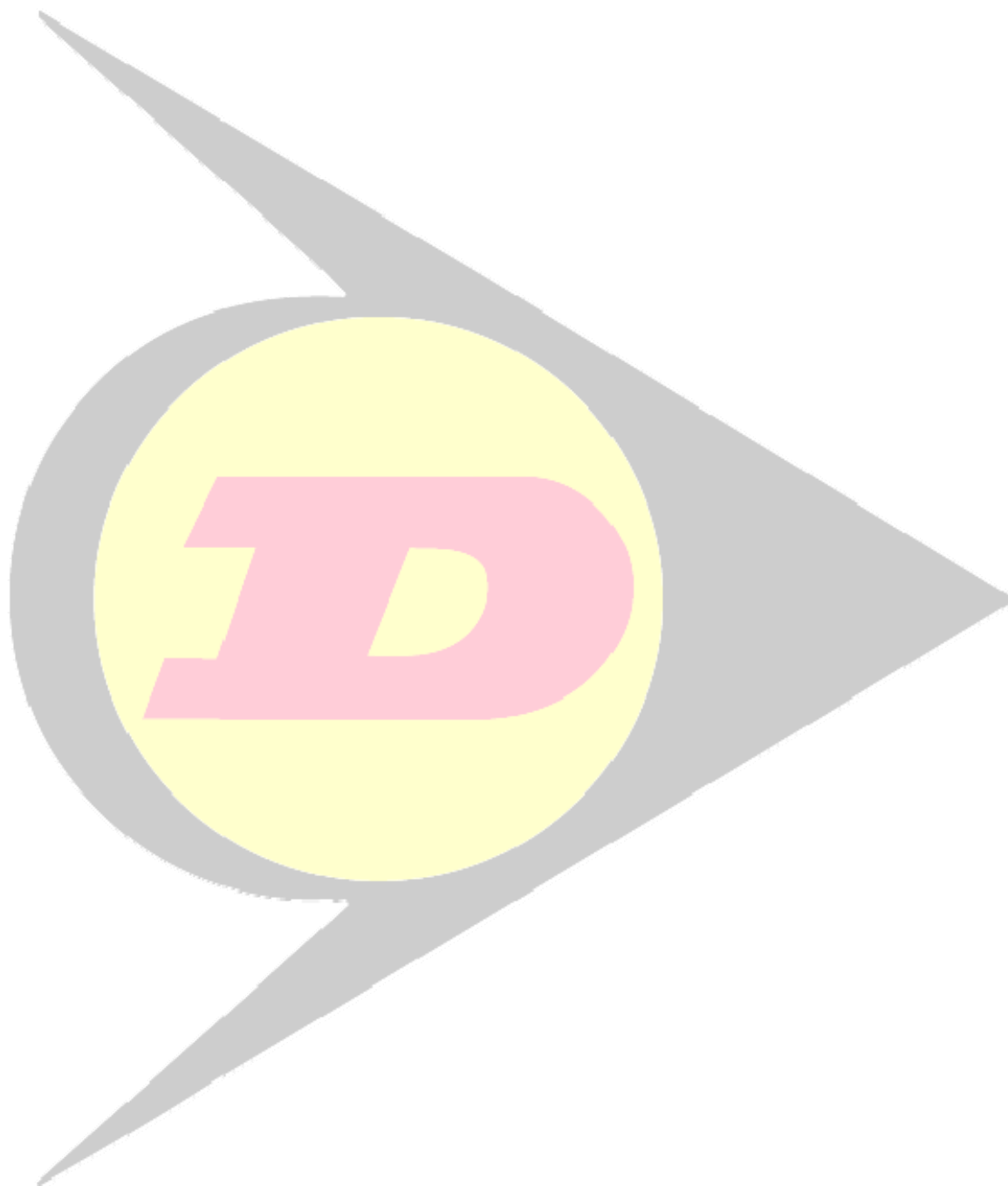

Dunlop Systems and Components
Het Wegdam 22
7496 CA Hengevelde
Nederland
Tel. +31 (0)547 33 30 65
Fax. +31 (0)547 33 30 68

Dunlop Systems and Components
Holbrook Lane
Coventry CV6 4QX
United Kingdom
Tel. +44 (0)24 7629 3300
Fax. +44 (0)24 7629 3390

www.dunlopsystems.com